

Self Contained Compactor



OWNER / OPERATOR INSTRUCTION MANUAL

Operation, Maintenance, and Installation

CRAM-A-LOT®
J.V. Manufacturing, Inc.
Solid Waste & Recycling Equipment



MODELS

SCR-T1

SCR-T2

SCR-02



“Equipping The World For A Better Environment”

Congratulations

You have just purchased a quality designed and manufactured CRAM-A-LOT® Compactor. Manufacturing compactors and balers since 1978, J.V. Manufacturing offers quality workmanship, factory trained installation and a national service network. Advanced features have been designed into the compactor for modern waste disposal operations.

As with any investment, a return is expected, and the return received from this investment will be in the form of maximum performance during many years of dependable service.

In order to maintain quality performance and safe operation of your new compactor, it is necessary to observe and practice the operation and maintenance information provided in this manual.

The employer involved in the operation, maintenance, and installation of the compactor should read and understand the most current version of the following applicable standards.

ANSI Standard No. Z245.2, "Stationary Compactors-Safety Requirements for Installation, Maintenance and Operation".
A copy of this standard may be obtained from:
ENVIRONMENTAL INDUSTRIES ASSOCIATION
4301 Connecticut Avenue, NW
Washington D.C. 20008
Website <http://www.wastec.org>

If, after thoroughly reading this manual, there are questions about the operation or repair of your compactor, please contact J.V. Manufacturing, Inc., and our Customer Support Team will provide assistance.

CRAM-A-LOT® Customer Support

Tel: 800-754-4290

Fax: 479-751-7870

Hours: 7:00 am - 5:00 pm CST®

Monday - Friday

Service@jv.com

JV Manufacturing Corporate Philosophy

It is the stated goals of J.V. Manufacturing, Inc. to build equipment of uncompromising quality, provide the absolute best customer service in our industry, and to conduct all business with honesty and integrity, whether it be with customers, vendors, fellow employees or members of the community.

J.V. Manufacturing, Inc. encourages positive change. Change will provide opportunities for future growth and new directions as we move into the future.

Table of Contents

Manual0007 Rev. B. Effective 01-12-06

Introduction	3-8
Congratulations	3
Table of contents	5
Specifications	6-7
Operation Section	9-18
Decals	10
Safety Decal Placement	11
Compactor Operation	
Safety Orientation.....	12
Owner/employer Responsibilities	13
Operator and Employee Responsibilities	14
Procedure for control of hazardous energy sources.....	14
Safety and Training program	15
General Training.....	15
Compactor Controls	16
Standard Operation Sequence.....	17
Emergency Procedures.....	17
User Preventive Maintenance	18
Maintenance Section	19-27
Lockout & Tag-out Instructions	20
Hydraulic Safety	21
Preventive Maintenance	22
Checking and adding oil	23
Pressure Setting Procedure	23
Electric Schematics	24
Hydraulic Schematics	25-26
Trouble-Shooting Chart	27
Parts Section	28-29
Lockout & Tag-out Instructions	29
Installation Section	30-32
Installation Requirements	
Concrete Pad.....	31
Positioning.....	31
Anchoring	31
Electrical & Hydraulic Installation.....	32
Hauler Section	33-34
Hauler Operation Instructions	34
Warranty Policy & Procedures Section	35-38
Warranty Policy.....	36-37
Warranty Procedures.....	38

Specifications

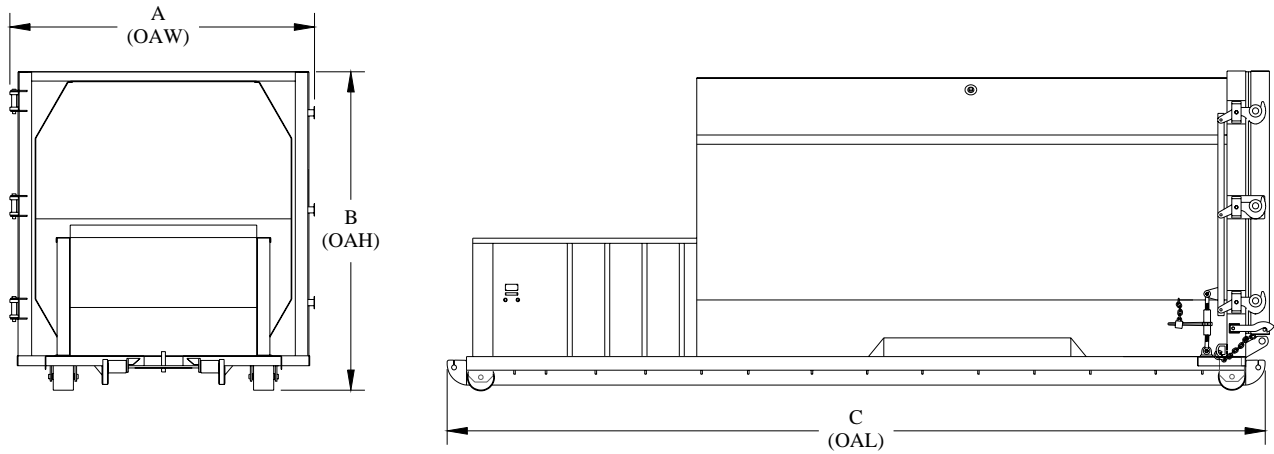

MODEL	A (OAW)	B (OAH)	C(OAL)	WEIGHT (lbs)
SC-T1-10	8'-1"	7'-3"	12'-11"	6,500
SC-T1-15	8'-1"	7'-3"	16'-3"	7,000
SC-T1-20	8'-1"	7'-3"	19'-7"	7,500
SC-T2-20	8'-8"	8'-8"	17'-1"	9,800
SC-T2-25	8'-4"	8'-8"	19'-8"	10,200
SC-T2-30	8'-4"	8'-8"	21'-10"	10,600
SC-T2-34	8'-4"	8'-8"	23'-6"	10,800
SC-T2-38	8'-4"	8'-8"	25'-7"	11,000
SC-02-20	8'-8"	8'-8"	18'-9"	10,000
SC-02-25	8'-8"	8'-8"	21'-4"	10,400
SC-02-30	8'-8"	8'-8"	23'-6"	10,800
SC-02-34	8'-8"	8'-8"	25'-2"	11,000

J.V. MANUFACTURING, INC

SC-02, SC-T1 and SC-T2 SPECIFICATIONS

General Equipment Specifications		SC-02	SC-T1	SC-T2
Wastec Charge Box Rating		1.31 cu/yd	.73 cu/yd	1.52 cu/yd
Clear Top Opening		34"x58"	31"x46"	41"x58"
Cycle Time (sec)		37	28	42
System Pressure (psi)	Normal	2,000	2,000	2,000
	Maximum	2,400	2,400	2,400
Compaction Force (lbs)	Normal	39,300	44,200	42,600
	Maximum	47,100	53,000	51,100
Ram Face Pressure (psi)	Normal	22.6	40	24.5
	Maximum	27.1	48	29.5
Ram Penetration		5.5"	6"	8"
Motor (hp)		10	10	10
Motor (voltage)		208/230/480 3ph	208/230/480 3ph	208/230/480 3ph
Pump (capacity) (gpm)		10.5	10.5	10.5
Reservoir capacity (gal)		22	22	22
Cylinder	Bore	5"	4" (2)	4" (2)
	Stroke	40"	26"	34"
	Rod	2.5"	2"	2"
Construction	Floor	1/2" steel plate	1/2" steel plate	1/2" steel plate
		4" "C" Channel	4" "C" Channel	4" "C" Channel
	Sides	3/16" steel plate	3/16" steel plate	3/16" steel plate
				2"x6"x3/16" steel tube
		6" "C" Channel	4" "C" Channel	4" "C" Channel
Breaker Bar	6"x6"x3/4" steel angle	6"x6"x1" steel angle	6"x6"x1" steel angle	
Ram	Top	3/16" steel plate	3/16" steel plate	3/16" steel plate
	Sides	1/4" steel plate	3/16" steel plate	1/4" steel plate
	Bottom	1/2" AR steel plate	1/2" AR steel plate	1/2" AR steel plate
	Face	3/8" wedge face steel	1/2" steel plate	1/2" steel plate
	Guides	UHMW pads	UHMW pads	UHMW pads

Operation Section

SAFETY DECALS



SAFETY DECAL PLACEMENT

ITEM	PART NO	DESCRIPTION	QTY
1	00440040	DECAL, DANGER DO NOT ENTER	3
2	00440043	DECAL, FIRE PORT	2
3	00440049	DECAL, CAUTION DISC HYD LINES	2
4	00440055	DECAL, CRAM-A-LOT	2
5	00440200	DECAL, WIPE SEAL	2
6	00440300	DECAL, COMPLIES WITHE ANSI Z245	1
7	00440310	DECAL UL LISTED SERIAL#	1
8	00440510	DECAL, DANGER DISC&LOCK OUT PWR	3
9	00440600	DECAL, WASTEC	1
10	00440870	DECAL, NOTICE RERROUTE INTERNAL	1

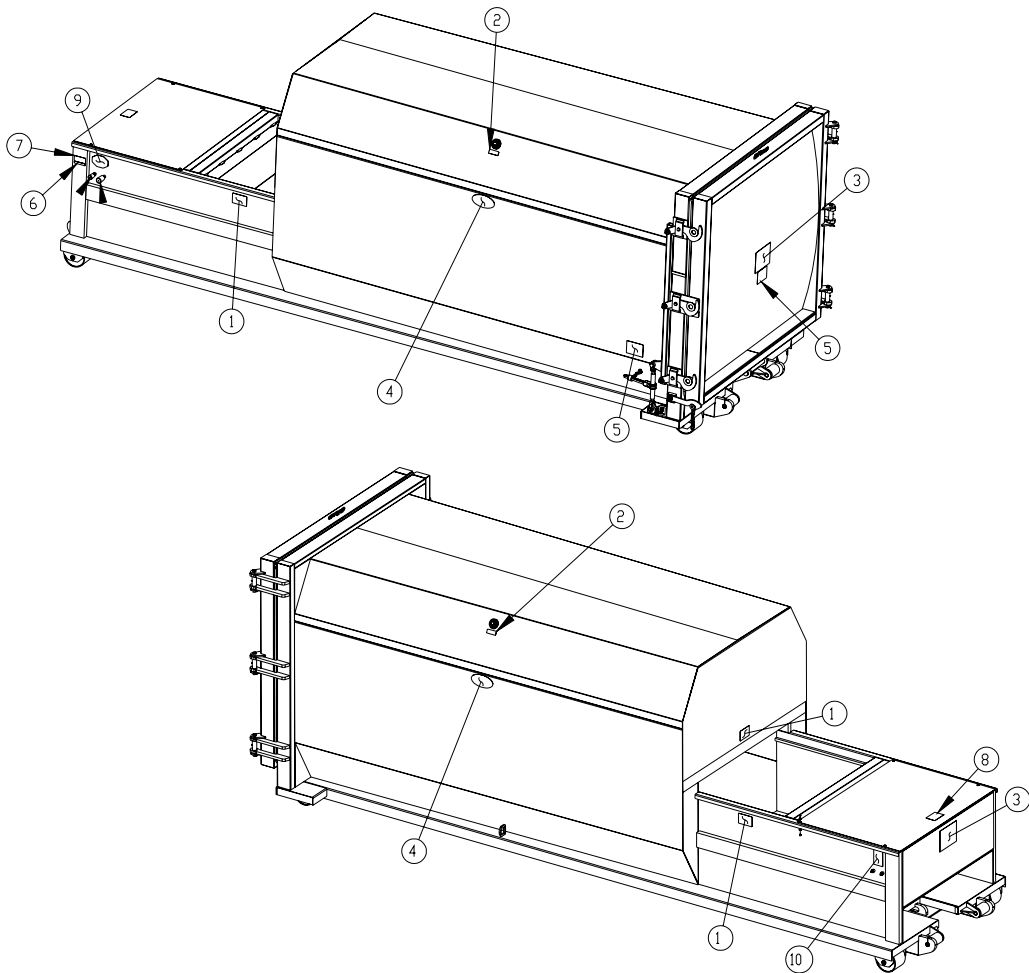

 CRAM-A-LOT	
<small>J.V. MANUFACTURING INC. (501) 751-7320</small>	
<small>701 HWY 265, P.O. BOX 229, SPRINGDALE, AR 72765</small>	
<small>DATE: 04/11/04</small>	
<small>BY: J.V. TAPPEL</small>	
<small>DATE: 09/16/04</small>	
<small>TYPICAL T2 SELF-CONTAINED COMPACTOR</small>	
DRAWING NO.	SCT2B001

Compactor Operation

Safety Orientation

Safe Operation

CRAM-A-LOT[®] compactors meet or exceed all safety standards set by ANSI. Although we have included many safety features in the design and construction of your compactor, safe operation of the equipment depends on the operator's adherence to certain guidelines. To prevent accidents to personnel or damage to the compactor, the operator must **NEVER VIOLATE ANY OF THE FOLLOWING SAFETY PRECAUTIONS**. It is the owner / employer's responsibility to ensure these guidelines are known and followed by all operators of the compactor.

NOTE: Publication of these safety precautions does not imply or represent an inclusive list.

NEVER place hands or arms in the compactor while it is operating.

NEVER allow anyone except qualified electrical or hydraulic repair persons to work on the equipment.

NEVER disable any safety switch.

NEVER overload the compaction chamber.

NEVER place concrete, heavy steel plate or castings, explosive materials, liquids, nor hazardous waste in the compactor .

NEVER climb in or on the compactor, nor perform any maintenance/repairs unless the power is disconnected and locked / Tagged out.

NOTE: Hydraulic oil is the primary element of power transmission on the compactor. Remember that hydraulic systems can remain pressurized even after the motor has stopped and or the power disconnected. Refer to the Lock Out / Tag Out instructions found elsewhere in this manual for instructions concerning the neutralization of these energy sources.

Z245.2—2004

Stationary compactors—safety requirements for installation, maintenance and operation.

Obtain a copy of this standard (ref: <http://www.wastec.org>) and become familiar with specific responsibilities and guidelines.

Safety Terminology

The accident prevention decals on your **CRAM-A-LOT**[®] compactor meet or exceed standards set by ANSI and OSHA. It is important that you are familiar with the terminology used on the decals and the varying degrees of hazards that are associated with this terminology.

DANGER—Indicates an imminently hazardous situation which, if not avoided, will result in death or serious injury. This signal word is to be limited to the most extreme situations. The signal word Danger should not be used for property damage hazards unless personal injury risk appropriate to the level is also involved.

WARNING—Indicates a potentially hazardous situation which, if not avoided, could result in death or serious injury. This signal word should not be used for property damage hazards unless personal injury risk appropriate to this level is also involved.

CAUTION—Indicates a potentially hazardous situation which, if not avoided, may result in minor or moderate injury. It may also be used to alert against unsafe practices that may also cause property damage.

NOTICE—Indicates a statement of company policy directly or indirectly related to the safety of personnel or protection of property. This signal word should not be associated directly with a hazard or hazardous situation.

Compactor Operation, cont.

Owner/employer responsibilities for compactors The employer/owner shall provide properly Maintained stationary compactors that meet all applicable regulatory safety requirements and requirements of ANSI Z245.2-2004.

- A Ensuring that the installation of the compactor conforms to local codes, ordinances, and manufacturer's recommendations. If installing into a system, examine prevailing safety standards of associated equipment.
- B Providing to employees instruction and training in safe work methods before assigning them to operate, clean, service, maintain, modify, or repair the compactor. Such instruction and training shall include procedures provided by the manufacturer. The employer will maintain records as to the names of employees and the dates of training.
- C Providing instructions for addressing abnormal situations (e.g., bridging of the loading chamber or feeding chute, jam of materials).
- D Assigning only trained employees to work on (which includes operating, loading, cleaning, servicing, maintaining, or repairing) the compactor.
- E Monitoring the employee's operation of the compactor and take appropriate action to insure proper use, including adherence to safe practices and the employee requirements of ANSI Z245.2-2004.
- F Repairing, prior to placing the compactor into service, any mechanical malfunctions or breakdowns that effect the safe operations of the compactor.
- G Establishing and following a program of periodic and regular inspections of all compactors to insure that all parts, component equipment, and safeguards are in safe operating condition, and adjusted, in accordance with the manufacturer's recommended procedures. This shall include keeping all malfunction reports and records of inspections and maintenance work performed.
- H Implementing a program for the maintenance of the compactor which will incorporate the following elements:
 - 1) Requirements for trained, competent maintenance employees or contractors to perform inspection and repair work;
 - 2) Providing for the cleaning, inspection and repair of the compactor in accordance with the manufacture's recommendations. Including periodic maintenance;
 - 3) Ensuring that all required safety features are operational and functioning, and repairing, prior to placing into service, any reported malfunction or defect that affects the safe operation of the compactor;
 - 4) Ensuring that all caution, warning and danger markings required are installed and legible, or are replaced if damaged, defaced or missing.
- I Utilizing the manufacturer's recommended procedures for the control of hazardous energy sources (lockout/tag-out) in a program complying with Part 1910.147 of the Title 29 of the Code of Federal Regulations (OSHA).
- J Utilizing the manufacture's recommended procedures for access control for permit-required confined spaces as part of the employer's program;
- K Protecting any person by one of the methods in 5.9.1, AMERICAN NATIONAL STANDARD Revision of ANSI Z245.2-2004, or by other means as effective as those means of protection.
- L For compactors fed by means of a loading pit conveyor, reciprocating floor or push pit that is flush with or below the facility floor, provide:
 - 1. Protection for employees by means of ;
 - a) Limiting access within 6 feet (183) of the edge of the pit to authorized employees;
 - b) Training authorized employees to recognize and avoid the hazards associated with the pit area;
 - c) Requiring that others whose employees use the pit area provide assurance of such training;
 - d) Limiting access by unauthorized persons by installing signs, such as:
"RESTRICTED AREA - AUTHORIZED EMPLOYEES ONLY"
 - 2. Providing a device to the extent practicable, which prevents trucks or other motor vehicles that unload directly into the loading pit from rolling into the pit.
- M When compactor equipped with automatic start/cycling controls are provided, allowing their use only in locations where a startup alarm is utilized or it is demonstrated that automatic starting does not result in a risk of injury to persons;
- N Providing guard railings for dock ramps that meet U.S. Occupational Safety and Health Administration requirements. These shall be located around the loading chamber if walk on ramps are used to deposit refuse into the loading chamber. Guard railings and toe boards shall be provided on the sides of docks and ramps;
- O Providing for an adequate work area around the compactor for safe maintenance, servicing, and cleaning procedures.
- P Keeping all surrounding walking areas and floor free from obstructions, and from accumulations of waste matter, grease, oil and water;
- Q Specifically inspecting safety interlocks, switches, and other protective devices to ensure that these devices are not disabled or bypassed, and not to permit the compactor to be operated unless these devices are fully functional. These inspections shall be in accordance with 'G';
- R Ensuring that containers supplied are capable of withstanding the maximum forces generated by the compacting system;
- S Ensuring that loaders are aware of hazards and safety requirements;
- T Ensuring that only authorized employees (18 years or older) operate, inspect, or maintain compactors;
- U Ensuring that only authorized employees (16 years or older) load, but do not operate compactors; and
- V Incorporating compactors into the employer's safety program.

Compactor Operation, cont.

Operator and employee responsibilities for compactors Operators who work on and around the compactor shall be responsible for the items listed below:

- A. Using all applicable safety features provided on the compactor;
- B. Using the compactor only after receiving instructions;
- C. Reporting any damage to, or malfunction of the compactor by submitting a report to the employer or responsible authority when the damage or malfunction occurs;
- D. Ensuring that access doors and service openings covers are in place, secure, and/or locked before operation begins;
- E. Ensuring that the area of operation around container/cart lifting systems and the container will be clear of persons during all phases of the lifting operation prior to energizing the dumping system;
- F. Ensuring that all persons are clear of the compactor point of operation before actuating any compaction cycle controls or container/cart lifting system controls and being prepared to stop the compaction cycle or container dumping operation if necessary;
- G. Insuring that all persons are clear of the tailgate (on compactor-container combinations so equipped) before the tailgate is opened or shut. The operator shall warn all persons not to cross behind or under an open tailgate;
- H. Using the compactor in accordance with the manufacture's instructions, including ensuring the proper position of all locks, doors, guards, etc.;
- I. Ensuring that no one disables or bypasses safety interlocks, switches, or other protective devices and that the compactor is not operated unless these devices are fully functional;
- J. Locking out the unit when inspecting malfunctions, jams, or other problems arising from daily operations, servicing, or performing maintenance (except maintenance testing). The affected employee shall identify the type and magnitude of the energy that the compactor uses, shall understand the hazards, and know the methods to control the energy;
- K. Coupling and securing a compatible container to a compactor frame as specified by the compactor and container manufacturers);
- L. Operating, inspecting, and maintaining the compactor only if 18 years old or older and being properly instructed and trained;
- M. Loading, but not operating, the compactor only if 16 years old or older.

Procedure for the control of hazardous energy sources. (lockout/tag-out)

1. The owner/employer shall have a hazardous energy control (lockout/tag-out) procedure to follow when performing servicing and maintenance on compactors where the unexpected energization or startup of equipment, or release of stored energy could cause injury to employees.
2. The owner/employer shall utilize the instructions provided by the manufacturer for the control of hazardous energy sources. The lockout/tag-out procedure shall isolate and render safe all energy sources including electrical, mechanical, hydraulic, pneumatic, chemical, thermal or other potential energy sources (e.g., gravity, etc). It shall be used to ensure that the compactor is stopped, isolated from all potentially hazardous energy sources and locked out before employees perform any servicing or maintenance where the unexpected energization or startup of the compactor or release of stored energy could cause injury.
3. The lockout/tag-out procedure shall include but is not limited to the following:
 - a) Shutting down all power sources;
 - b) Removing keys or other devices that enable the compactor;
 - c) Installing a tag on an appropriate location, using a non-reusable fastener, or installing a similar warning device;
 - d) Placing operating components in such a position so as not to be subject to possible free fall and/or installation of additional blocking devices to prevent such free fall of any raised or elevated component;
 - e) Relieving stored hydraulic or pneumatic pressure, after blocking devices are installed, if maintenance is to be done to the hydraulic or pneumatic system.
4. The procedure shall address the following:
 - a) Sequence of lockout for the compactor;
 1. Notify all affected employees that servicing or maintenance is required on a compactor and that the compactor must be shut down and locked out to perform the servicing or maintenance.
 2. The authorized employee shall refer to the company procedure to identify the type and magnitude of the energy that the compactor utilizes, shall understand the hazards of the energy, and shall know the methods to control them.
 3. If the compactor is operating, it must be shut down by the normal stopping procedure (depress stop button, open switch, close valve, etc.).
 4. De-activate the energy isolating device(s) so that the compactor is isolated from the energy source(s).
 5. Lock out the energy isolating device(s) with assigned individual lock(s).
 6. Stored or residual energy must be dissipated or restrained by methods such as grounding, repositioning, blocking, bleeding down, etc.
 7. Ensure that the compactor is disconnected from the energy source(s) by first checking that no personnel are exposed, then verify the isolation of the equipment by operating the push button or other normal operating control(s) or by testing to make certain the equipment will not operate.
Caution; Return operating control(s) to neutral or "off" position only after verifying the isolation of the equipment.

NOTE: The machine or equipment is now locked out.

Compactor Operation, cont.

- b) Restoring the compactor to service. When the servicing or maintenance is completed and the compactor is ready to return to normal operating condition, the following steps shall be taken:
 1. Check the machine or equipment and the immediate area around the machine or equipment to ensure that all non-essential items have been removed and the machine or equipment components are operationally intact.
 2. Check the work area to insure that all employees have been safely positioned or removed from the area.
 3. Verify that the controls are in neutral.
 4. Remove the lockout devices and re-energize the machine of equipment.
NOTE: The removal of some forms of blocking may require re-energizing of the machine before safe removal.
 5. Notify affected employees that the servicing or maintenance is completed and the machine or equipment is ready for use.
5. Procedures for work in confined spaces:
 - a) The owner/employer shall have a written procedure for work in confined spaces meeting the criteria of "permit required confined spaces," such as integrated power units. The procedure shall utilize the manufacturer's instructions for the hazardous energy control (lockout/ tag-out) procedure which shall isolate and render safe energy sources, including electrical, mechanical, hydraulic, pneumatic, chemical, thermal or other potential sources of energy (e.g., gravity, kinetic, etc.), which may create a hazard during entry into each of those confined spaces
 - b) These instructions shall include the requirement to affix a sign to the compactor, at or near the entrances to those confined spaces for which hazardous energy control procedures are provided, such as, "**Warning — Follow lockout/tag-out procedures.**"
 - c) These instructions shall include the requirement to affix a sign to the stationary compactor, at or near the entrances to those confined spaces for which hazardous energy control procedures are provided, such as, "**Danger — Confined Space.**"

Safety and training program

General: Employers shall evaluate and manage safety issues related the operation of compaction equipment as part of their safety program

Safety Program

The employer's program shall include at a minimum the following elements:

- a) A hazard assessment in which the employer conducts a review of the various types of compaction equipment that the employer utilizes and the hazards associated with them and, review and assess the capabilities, qualifications and training of any person who may potentially encounter these hazards.
- b) An evaluation of the means and methods of controlling the hazards identified in the hazard assessment, including information such as industry and regulatory requirements, instructions for the operation, inspection, and maintenance of compactors, and other information appropriate to the hazards that are identified.
- c) A written program, based upon the hazard assessment and evaluation, to include procedure for the operation, inspection, and maintenance of compactors, prohibited practices, record keeping, training requirements, and normative references to documents, such as operating manuals, that are relied upon and may be required as part of that program.
- d) Periodic review and program revisions as necessary to ensure the effectiveness of the safety program.

General training

Employers shall ensure all employees, including supervisors, contract laborers, and all other persons engaged in the operation, cleaning, maintenance, service or repair of compacting equipment are properly trained appropriate for their assigned jobs and tasks. Contractors who may be engaged to operate or maintain the employer's compactor shall be advised of the unique hazards related to the equipment that may affect the activities in which the contractor's employees will engage.

Compactor Operation, cont.

Compactor Controls

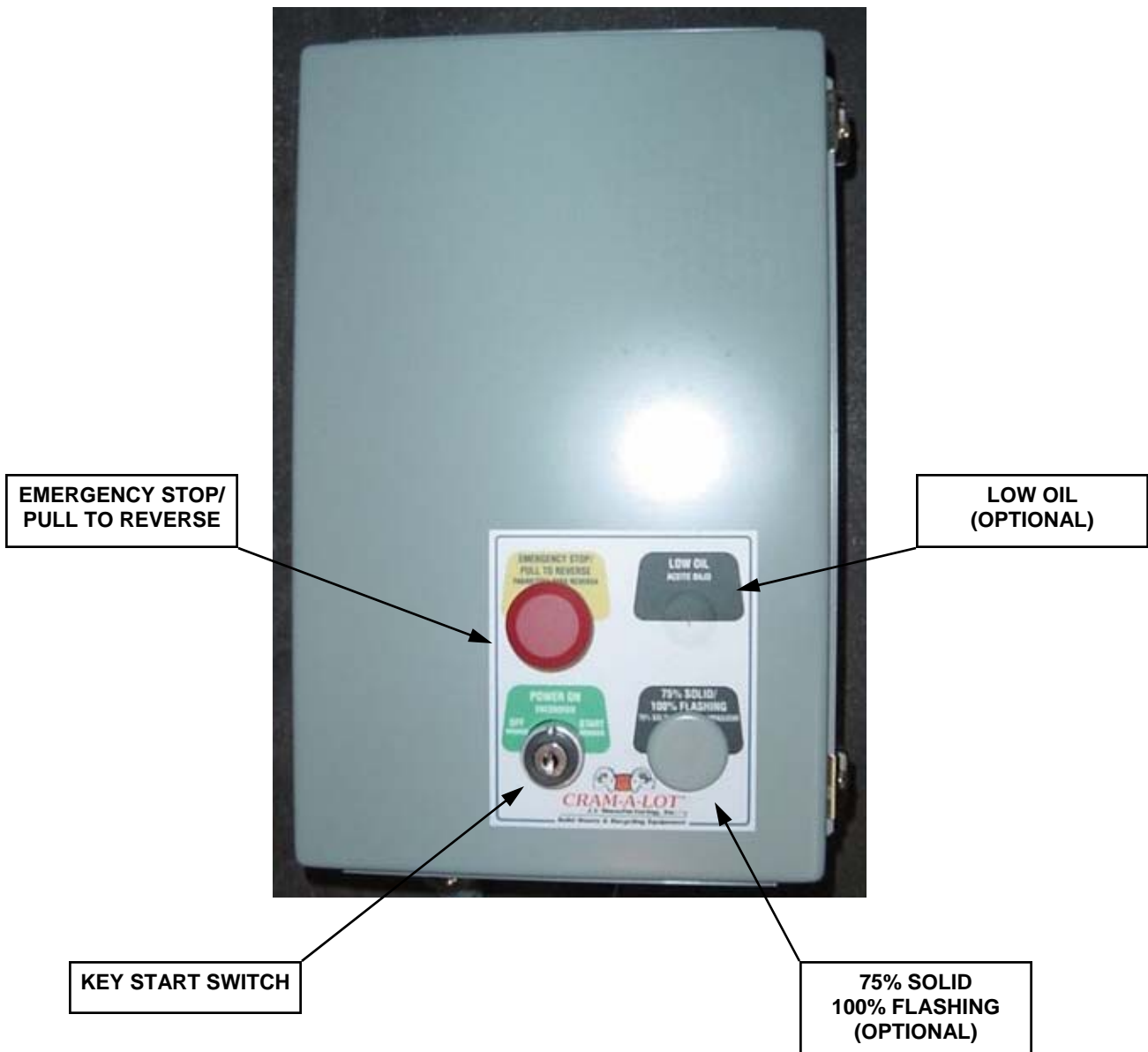

Compactor Operation, cont.



CAUTION

It is unlawful to operate this machine if you are under 18 years of age!

Emergency Procedures

Should an emergency occur while operating the compactor, press the RED EMERGENCY STOP BUTTON and the compactor will terminate all functions and shut down. **EVERYONE AUTHORIZED TO OPERATE THE COMPACTOR SHOULD KNOW THIS EMERGENCY PROCEDURE.**

Standard Operation

- 1) Open chamber door (If not chute fed.)
- 2) Fill charge chamber with material to be compacted.
- 3) Close chamber door.
- 4) Turn the "Start Key Switch"
- 5) Compactor will start and complete one cycle of operation.
- 6) The Compactor will continue to operate in this manner until the "Push to Stop" button is pressed or a door is opened. If the Compactor is stopped it must be restarted with the "Start Key Switch".
- 7) Repeat steps #1 thru #5 until the container attached to the compactor is full. Contact hauler for dumping.

Conditions During Standard Operation

- The "Push to Stop" button may be pressed at any time during the cycle to stop operation to shut down the system. If this button is pulled at any time during the cycle or when the compactor is stopped with the platen forward away from the retracted position, the platen will return to the retracted position and the compactor will stop.

Note: pressing the stop button may reset the full indicator lights.

User Preventive Maintenance

USER PREVENTIVE MAINTENANCE

We recommend the user of *CRAM-A-LOT*[®] compactors adopt a program of regularly scheduled maintenance procedures. This schedule should be followed to insure against premature failure of mechanical or hydraulic components.

1. INITIAL CHECK:

- a. All nuts and bolts during the first week of use, and then monthly thereafter.
- b. Hydraulic reservoir should be at the mid to upper range of the sight glass with ram retracted. Use a good quality 5W-20 Hydraulic fluid.
- c. Hydraulic lines for leaks.
- d. Hydraulic hose condition. (Check for damage, kinks, etc.).
- e. Access covers to be sure fasteners are in place.
- f. Power unit. Remove dust and dirt from outside of control box. Wipe off any dirt or grease, oil or moisture.

2. MONTHLY CHECK:

- a. Check external hoses for chafing, rubbing, or other deterioration and damage.
- b. Check for any obvious unsafe conditions, such as electrical lines or operator obstructions, in compactor area. If any unsafe conditions are found, they should reported immediately to an authorized maintenance technician.
- c. Check oil level in hydraulic reservoir.
- d. Check functional operation of standard controls and options (stop button, timers, lights, etc.).

Authorized Technician Maintenance Section

Authorized Technician Maintenance

Lock-out & Tag-out Instructions

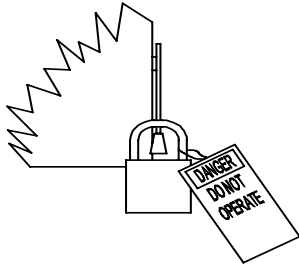

FORWARD: Before entering any part of the compactor, be sure that all sources of energy have been shut off, all potential hazards have been eliminated, and the compactor is locked-out and tagged-out in accordance with OSHA and ANSI requirements. If the ram is pressing against a load, move the ram rearward before shutting the compactor down. The specific lock-out and tag-out instructions may vary from company to company (i.e. multiple locks may be required, or other machinery may need to be locked-out and tagged-out). The following instructions are provided as minimum guidelines.

INSTRUCTIONS

1. Move the main disconnect lever to the OFF position.
2. Padlock the disconnect lever with a keyed padlock and take the key with you.
3. Along with the padlock, place an appropriate, highly visible, warning tag on the disconnect lever. The tag should provide a warning such as "Danger: Do not operate equipment. Person working on equipment" or "Warning: Do not energize without permission of _____".
4. After locking and tagging the compactor, try to start and operate the compactor (as outlined in the Operating Instructions) to make sure the lock-out and tag-out is effective. If the lock-out and tag-out is effective, remove the key from the key switch and take it with you.

ELECTRICAL: The motor control panel contains high voltage components. Only authorized service personnel should be allowed inside the panel. Authorized service personnel should be allowed inside the panel only after the compactor has been locked-out and tagged-out.

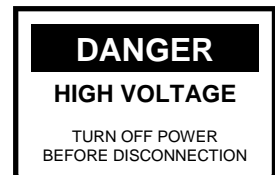

HYDRAULIC: Stored hydraulic energy must be removed from the compactor hydraulic circuit for complete lock-out and tag-out. Make sure that this energy has been relieved by manually depressing the solenoid valve pin located in the center of each coil end of the directional valve.

Manual Operating Pin (both ends).

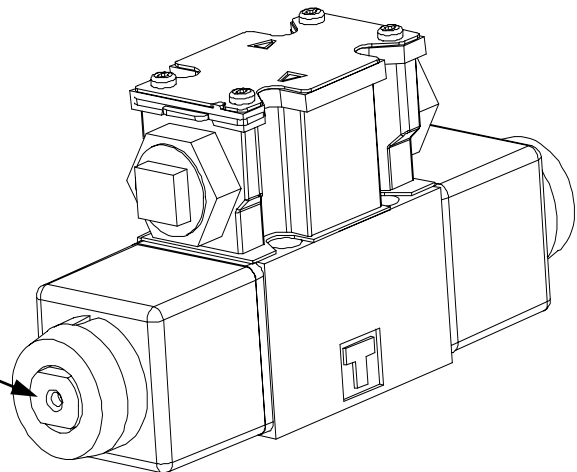

Authorized Technician Maintenance, cont.

HYDRAULIC SAFETY: PLEASE READ CAREFULLY!



Warning: Escaping fluid under pressure can penetrate the skin causing serious injury. Avoid the hazard by relieving pressure before disconnecting hydraulic lines. Tighten all connections before applying pressure. Search for leaks with a piece of cardboard. Protect hands and body from high pressure fluids.

If an accident occurs, see a doctor immediately. Any fluid injected into the skin must be surgically removed within a few hours or gangrene may result.

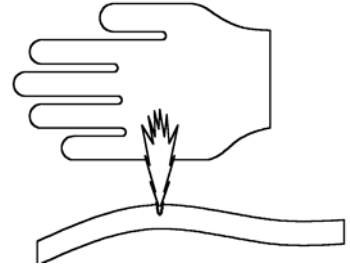

AVOID HEATING NEAR PRESSURIZED HYDRAULIC HOSES

Flammable spray can be generated by heating near pressurized hydraulic hoses, resulting in severe burns to yourself and bystanders. Do not heat by welding, or using a torch near hoses. Hose can be accidentally cut when heat goes beyond the immediate flame area.

THE FOLLOWING WARNINGS PERTAIN TO THE MORE COMMON ABUSES OF HYDRAULIC HOSE:

1. **INSPECT** the hose assembly before each use.
2. **REPLACE** the hose assembly immediately if:
 - a. The jacket of the hose appears abnormal.
 - b. You have reason to believe it may be abnormal.
 - c. There is any fluid leakage.
 - d. The couplings are damaged.
 - e. The hose is damaged or kinked.
 - f. The reinforcement is visible through the jacket.
3. DO NOT **EXCEED** the maximum recommended working pressure of the hose.
4. DO NOT **KINK** the hose assembly.
5. DO NOT **BEND** the hose assembly beyond its minimum recommended bend radius.
6. DO NOT **EXPOSE** to temperatures in excess of 225 degrees Fahrenheit.
7. DO NOT USE AS A **STRENGTH MEMBER** for pulling or lifting equipment.



Caution: If replacing hydraulic hose, use only hose that meets or exceeds 3,000 PSI working pressure.

IMPORTANT: REPAIR OF HYDRAULIC CYLINDERS SHOULD BE MADE BY AN AUTHORIZED DEALER.

Authorized Technician Maintenance, cont.

PREVENTIVE MAINTENANCE

We recommend the user of *CRAM-A-LOT*[®] compactors adopt a program of regularly scheduled maintenance procedures. This schedule should be followed to insure against premature failure of mechanical or hydraulic components.

1. INITIAL CHECK:

- a. All nuts and bolts during the first week of use, and then monthly thereafter.
- b. Hydraulic reservoir should be at the mid to upper range of the sight glass with ram retracted. Use a good quality 5W-20 Hydraulic fluid.
- c. Hydraulic lines for leaks.
- d. Hydraulic hose condition. (Check for damage, kinks, etc.).
- e. Access covers to be sure fasteners are in place.
- f. Power unit. Remove dust and dirt from outside of control box. Wipe off any dirt or grease, oil or moisture.

2. MONTHLY CHECK:

- a. Check external hoses for chafing, rubbing, or other deterioration and damage.
- b. Check for any obvious unsafe conditions, such as electrical lines or operator obstructions, in compactor area.
- c. Check oil level in hydraulic reservoir.
- d. Check functional operation of standard controls and options (stop button, timers, lights, etc.).
- e. Check hydraulic cylinder and internal hoses for leakages, hoses for chafing and wear.

4. YEARLY CHECK:

- * a. Electrician to check all electrical connections, check motor resistance (recording successive readings helps prevent future failure), Under heavy use, grease the motor. (DO NOT OVER-GREASE).
- b. Hydraulic system—prior to winter season, drain, replace filter, and clean inside of reservoir by removing drain plug. Replace plug and refill. Check for tightness. Refill reservoir with high quality 5W-20 Hydraulic fluid.
- c. Check structure for potential trouble areas and repair as needed.
- d. Check hoses to insure that they do not become severely worn before being replaced. A broken hose will allow the reservoir to be pumped dry and ruin the pump.
- * e. Check condition of ram guide shoes. Replace if necessary. **Keeping the slide material replaced when necessary will greatly extend the life of the compactor floor and sides.**

LUBRICATION:

NOTE: Clean-out or maintenance requires the loading chamber cover be open, but be sure the compactor ram is extended first. To EXTEND the ram - first turn the "start" switch and fully extend the ram. When ram is fully extended, press the "STOP" button, and remove the key, **lockout/tag-out** the power, then the cover can be removed.

- *  **Warning:** Before removing any access panels or entering charge chamber, make absolutely sure main disconnect power box is shut off and locked, with key to said lock in possession of person entering charge chamber or area behind bolted access covers. A tag should also be attached to the disconnect stating "UNDER REPAIR, DO NOT USE", with persons name on the tag who is entering behind the ram.

Open the access cover on the top of the compactor by removing the attached bolts. When lubrication or maintenance is complete, replace the cover before any operation.

-  **Warning:** This procedure is for maintenance only. All access covers shall be replaced and bolted into position after lubrication or clean-out.

Authorized Technician Maintenance, cont.

Checking and adding oil.

Time: 30 minutes

Tools: Clean funnel

Parts: SAE 5W-20 high grade hydraulic oil (Sun 2105 or equivalent)

Supplies: Disposable shop towels.

Tips: Make sure the ram is fully retracted when checking and filling with oil.

Be patient when filling with oil.

The cleanliness of the oil is very important to the long term reliability of the hydraulic system.

Checking the oil level.

1. Run the machine to place the ram in the fully retracted position.
2. Check the oil by looking at the sight gauge on the side of the oil tank. If the oil level is below the black fill line on the gauge, oil needs to be added to the tank.

Adding oil.

1. **IMPORTANT!** - Follow all lockout/tag-out procedures before continuing this service procedure.
2. Using a disposable shop towel, clean any dust and debris from around the oil fill port to prevent contaminants from entering the hydraulic system.
3. Remove oil fill cap.
4. Using clean funnel, pour oil into the port until oil lever has reached the black fill line on the oil sight gauge.
5. When the oil level reaches the black fill line, remove the funnel, replace the oil fill cap.
6. Clean any spilled oil off the machine with a disposable shop towel.
7. Remove the lockout/tag-out according to procedures and restore power to unit.
8. Check unit operation.

Pressure Setting Procedure.

Authorized Technician Maintenance, cont.

Electrical Schematic

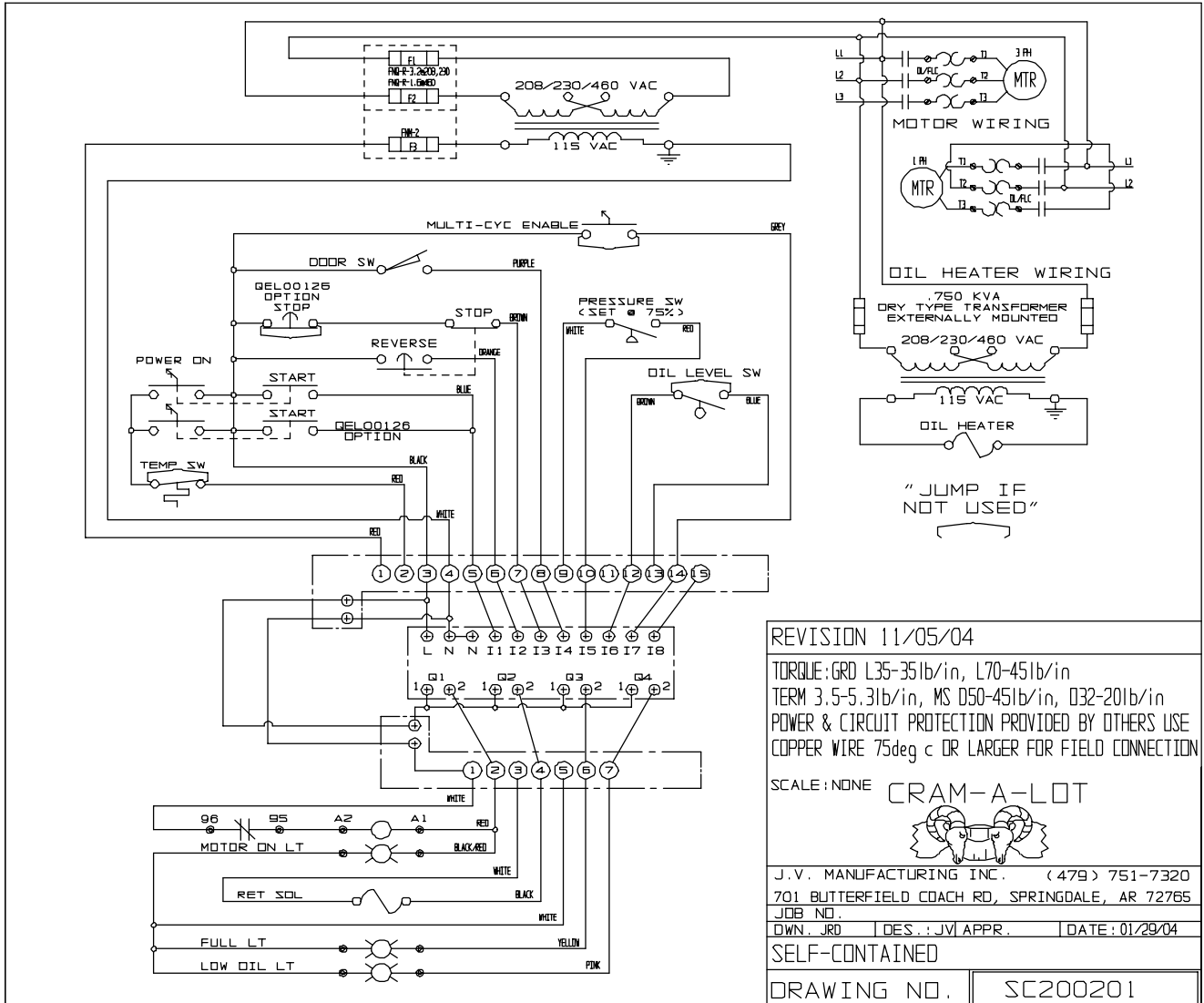

MDL	VOLTAGE		VOLTAGE			VOLTAGE		VOLTAGE			VOLTAGE			VOLTAGE					
SN	5 HP		5 HP 3PH 60HZ			10 HP		10 HP 3PH 60HZ			15 HP 3PH 60HZ			20 HP 3PH 60HZ					
DATE	1PH 60HZ	240	208	240	480	575	208	240	208	240	480	575	208	240	480	575	208	240	480
BUILT BY	240	208	240	480	575	208	240	208	240	480	575	208	240	480	575	208	240	480	
FULL LOAD CURRENT-AMPS	23	15	14	7	5.7	45	40	28	26	13	10.3	40	38	19	17	56	52	26	
MINIMUM CIRCUIT AMPACITY	29	19	17	8	8	57	50	35	32	16	13	50	47	24	21	70	65	32	
MAX OVCLUR DEV TIME DELAY FUSE-AMPS	50	35	30	15	15	100	90	60	60	30	23	90	85	45	38	125	100	60	
MINIMUM WIRE SIZE (AWG)	10	12	14	14	14	6	8	8	8	12	10	6	6	10	10	4	4	8	

Authorized Technician Maintenance, cont.

Hydraulic Schematic

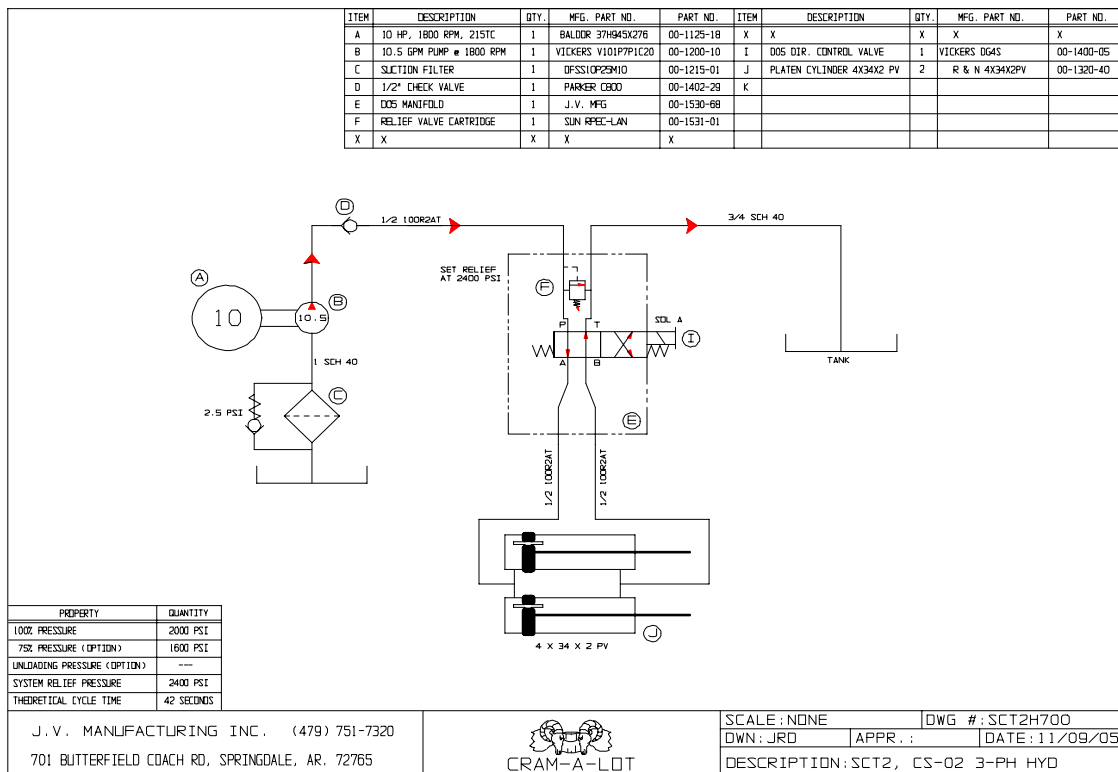
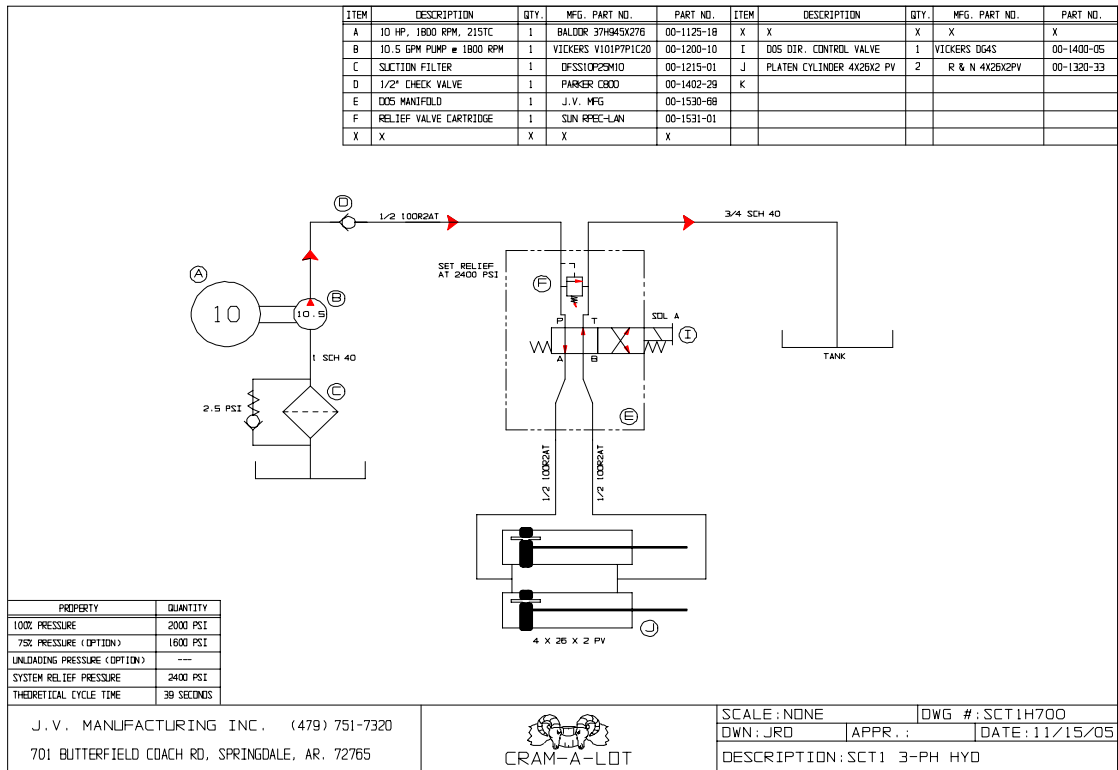

Authorized Technician Maintenance, cont.

Hydraulic Schematic

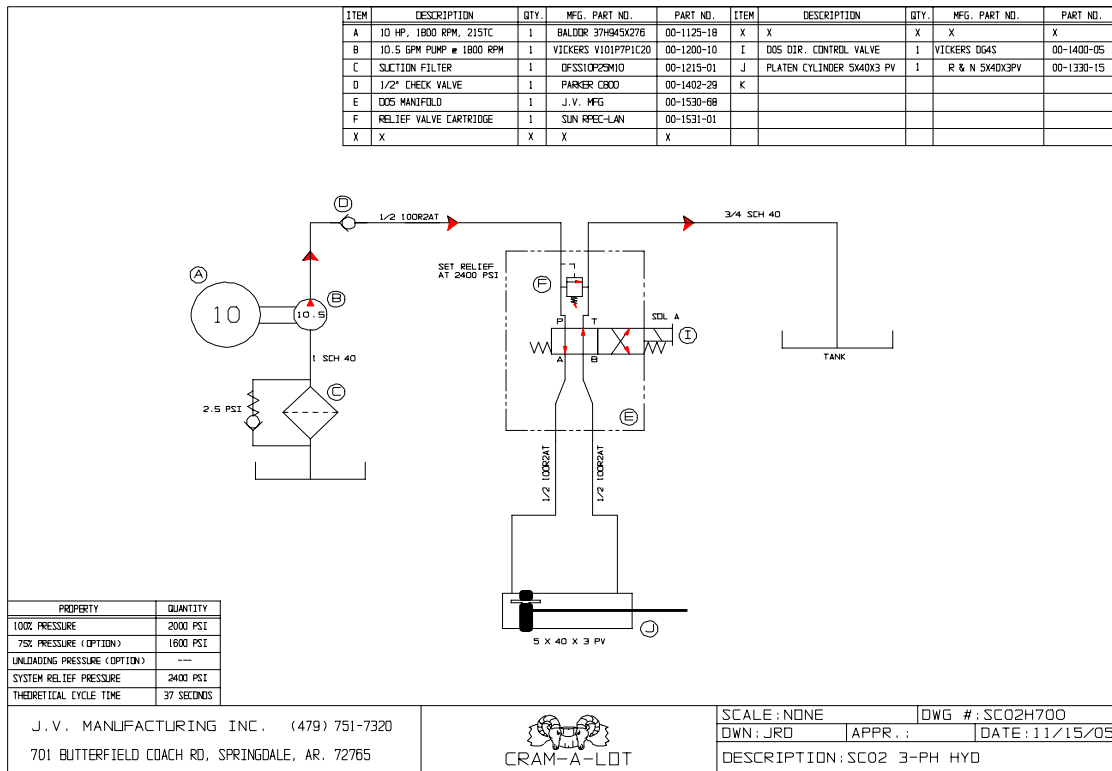

Authorized Technician Maintenance, cont.

TROUBLE-SHOOTING CHART

Note: Before performing any maintenance, always **LOCK AND TAG-OUT THE DISCONNECT.**

Problem

Solution

Motor will not operate.

1. Check main breaker.
2. Check fused disconnect.
3. Check motor starter thermal overloads. Reset if necessary.
4. Check motor starter coil.
5. Check magnetic door switch (if applicable).

Motor runs but ram does not move.

1. Check for proper motor rotation. (clockwise from the fan end).
2. Check hydraulic fluid level.
3. Check hydraulic hose connections from power unit to compactor.
4. Check the directional valve for proper operation.
5. Check relief valve for proper adjustment.
6. Check the limit switch.

Compactor shifts erratically.

1. Check for proper system pressure.
2. Check for proper pressure switch adjustment.
3. Check directional valve.

Compactor makes excessive noise.

1. Check hydraulic fluid level.
 2. Check ram guide for lubrication.
 3. Check for water or air in hydraulic fluid.
 4. Check oil filter and suction line components for tightness.
-

Parts Section

SAFETY DECAL PLACEMENT

ITEM	PART NO	DESCRIPTION	QTY
1	00440040	DECAL, DANGER DO NOT ENTER	3
2	00440043	DECAL, FIRE PORT	2
3	00440049	DECAL, CAUTION DISC HYD LINES	2
4	00440055	DECAL, CRAM-A-LOT	2
5	00440200	DECAL, WIPE SEAL	2
6	00440300	DECAL, COMPLIES WITHE ANSI Z245	1
7	00440310	DECAL UL LISTED SERIAL#	1
8	00440510	DECAL, DANGER DISC&LOCK OUT PWR	3
9	00440600	DECAL, WASTE	1
10	00440870	DECAL, NOTICE REROUTE INTERNAL	1

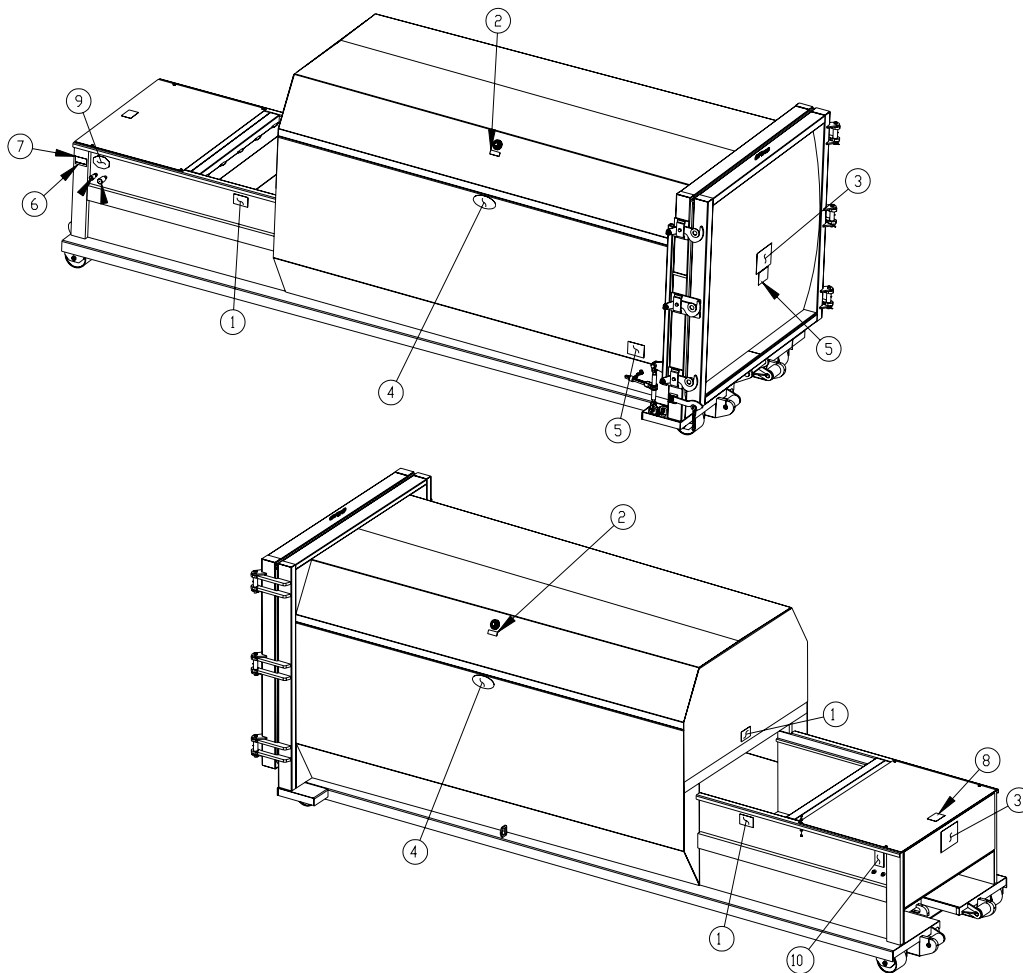

CRAM-A-LOT			
J.V. MANUFACTURING, INC.	CS01 751-7320		
701 HWY 2656, P.O. BOX 229, SPRINGDALE, AR 72765			
2001, MO			
HOWARD W. DESJAYZ, APPR	DATE: 09/16/04		
TYPICAL T2 SELF-CONTAINED COMPACTOR			
DRAWING NO.	SCT2B001		

Installation Section

Installation

CONCRETE PAD REQUIREMENTS

Caution:

Review this manual before making the installation. Study the job-site and installation requirements carefully to be certain all necessary safeguards and or safety devices are provided to protect all personnel and equipment during installation and as a completed system. Special attention is directed to the extract from American National Institute Z245.2.

These operating instructions are not intended as a substitute for training and experience in proper use and safety procedures in operating this equipment.

J.V. Manufacturing does not assume responsibility for the installation procedures of this equipment. Conformance to applicable local, state, and federal laws concerning installation rest with the customer.

CONCRETE PAD

1. Preferred dimensions of the concrete pad are 10 ft. wide and a 5' greater than length of compactor/container. It should be level and of minimum 3000 PSI concrete reinforced, 6 in. thick. It is preferred that the concrete pad be flush with the surrounding ground level.
2. To provide accessibility, concrete pad should be positioned to allow 2 ft 0 in between machine and building wall if installed parallel with building. Allow a minimum of 45 ft of clear space from end of pad for container handling vehicle.

Note: The clearances given are minimums. Your installation may require greater clearances depending on the site and the hauling equipment that will be used.

POSITIONING

Position the compactor so that sufficient room is available for proper and safe operation. The compactor should be placed no less than 24 inches from any structure.

ANCHORING

The compactor guide system should be anchored to the pad with anchor bolts (minimum 3/4" x 5-1/2"). To allow for construction variances, the holes should be drilled after locating the compactor in the desired position.

Installation, cont

ELECTRICAL & HYDRAULIC INSTALLATION



The motor control panel contains high voltage components. Only authorized service personnel should be allowed inside. See Lock-Out and Tag-Out instructions in the maintenance section.

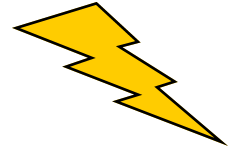

A lockable fused disconnect switch (customer furnished) must be installed and be within sight of the compactor motor control panel location, not to exceed 50' 0" from the compactor. This fused disconnect switch should be sized in accordance with the compactor.

GROUNDING INSTRUCTIONS

This appliance must be connected to a grounded, metal, permanent wiring system; or an equipment-grounding conductor must be run with the circuit conductors and connected to the equipment-grounded terminal or lead on the appliance. A qualified electrician should be consulted if there is any doubt as to whether an outlet box is properly grounded.

ELECTRICAL CONNECTIONS

1. Run power lines , between fused disconnect switch (customer furnished) and compactor's motor control panel, in accordance with local electrical codes, using knock-outs in bottom of motor control panel.
2. Check voltage at fused disconnect to be certain it is the same as is shown on compactor. If voltage is correct, put fused disconnect switch in "ON" position.
3. Check motor wiring, voltage, motor rotation.
4. Check motor starter, thermal overload selector and voltage.

START-UP INSTRUCTIONS

1. With the ram fully retracted, check to be sure the oil reservoir is full on the sight gauge. *Refer to the Maintenance Section for hydraulic oil recommendations*). The hydraulic system pressure has been factory set and the entire unit has been operated prior to shipment.
2. CAUTION: MAKE SURE PERSONS AND MATERIAL ARE CLEAR OF CHARGE BOX AREA.
3. Turn the start key and check the pump for proper rotation.
CAUTION: If pump rotates backward, stop immediately. The pump will be damaged if it is operated in reverse even for short periods. Reversing any two incoming power lines will change the motor/pump rotation on three phase power.
4. **Make sure that the operators are trained in the proper use of this equipment.**

Hauler Section

HAULER OPERATING INSTRUCTIONS

REMOVING SELF-CONTAINED COMPACTOR

1. Disconnect the two hydraulic hoses with quick disconnect couplings at the compactor (Packer end) and position them either over the power unit cover or on an appropriate hanger (not provided) to help prevent damaging the connectors and possibly contaminating the hydraulic system.
2. If applicable, disconnect the safety gate/hopper door interlock electrical cord from the outlet box located above the hydraulic quick disconnect couplings on the compactor. Connect the cord to the blank outlet box to insure a rain-tight seal while the compactor is being hauled. The blank outlet box is located on the power unit.
3. Shut all loading doors and/or safety gates.
4. Ensure that compactor's understructure matches that of the hauling vehicle.
5. Hook vehicle's lifting cable or lifting hook securely on compactor understructure.
6. **Pull compactor completely away from hoppers and chutes before lifting upward.**

RE-INSTALLING SELF-CONTAINED COMPACTOR

1. Align compactor with guide system and slowly let compactor return to position. Check for proper alignment of the hoppers.
Never allow or force compactor to roll past wheel stops.
2. Remove lifting device from understructure.
3. Reconnect the two hydraulic hoses with quick disconnect couplings at the compactor (Packer end) and if applicable, reconnect the electrical cord in the outlet box on the compactor.
4. Clear area around compactor.

Warranty Policy And Procedure Section

Warranty Policy

TERM

Unless terminated as hereinafter provide, this warranty shall continue in full force for a period of three years, and shall govern all transactions between the parties hereto following the completion of installation of the product at the end user's facility, and evidenced by a signed and dated installation report and warranty registration returned to J.V. Manufacturing, Inc. If no registration card is remitted or the installation is not provided by the factory, the warranty period shall be considered to start on the date of shipment.

As limited herein, the *CRAM-A-LOT*[®] products (the "*goods*") you have purchased are warranted by J.V. Manufacturing, Inc. ("*seller*") through the specified period to be free of defects in material and workmanship. This warranty does not apply to any damage caused by negligence, misuse, modifications, alterations, or accidents by purchaser or third parties.

Owning *CRAM-A-LOT*[®] quality is as easy as 1-2-3! J.V. Manufacturing, Inc will furnish without charge:

- 1) All parts and labor expenses through the first year of ownership to remedy any faults proven to be the result of defective materials or workmanship.
- 2) All parts through the second year of ownership to remedy any faults proven to be the result of defective materials or workmanship.
- 3) All labor expenses through the third year of ownership to remedy any structural faults proven to be the result of defective materials or workmanship.

LIMITED WARRANTY

Seller's liability under warranty shall be limited to the repair and replacement of parts and the necessary labor and services required to repair the goods and shall be in lieu of any other remedy available under applicable law and shall not to exceed the purchase price of the goods. IT IS EXPRESSLY AGREED THAT THIS WARRANTY WILL BE IN LIEU OF ALL OTHER WARRANTIES WHETHER EXPRESS OR IMPLIED, OF FITNESS AND IN LIEU OF THE WARRANTY OF MERCHANTABILITY, AND ALL SUCH OTHER WARRANTIES ARE HEREBY REVOKED AND DISCLAIMED. **WARRANTY "VOID" UPON NON-PAYMENT.**

- Seller neither assumes nor authorizes any representative or person to assume for seller any other liability in connection with the sale or shipment of our products.
- Seller reserves the right to make changes or improvements in our products without notice and without incurring any obligation to prospective customers.
- Seller reserves the right to make changes or improvements in our products without incurring any obligation to similarly alter products previously purchased.
- Except in the case of damages or defect attributable to the Seller, Buyer shall not make any claim against Seller for any damaged or defective product or part.
- If Seller breaches or repudiates this contract, Buyer shall not be entitled to recover any incidental damages as that term is defined in the Uniform Commercial Code.
- If Seller breaches or repudiates this contract, Buyer shall not be entitled to any consequential damages as defined in the Uniform Commercial Code.
- Seller does not warrant that any product purchased shall conform to: (1). any affirmation of fact or promise relating to it, or (2). any description of it. No affirmation, promise, or description relating to any product purchased shall be deemed part of the basis of the parties bargain.
- No agent, employee, or representative of Seller has any authority to bind Seller to any affirmation, representation, or warranty concerning the goods sold under this contract, and unless an affirmation, representation, or warranty made by agent, employee, or representative is specifically included within this contract, it will not be enforceable by Buyer.

ITEMS NOT COVERED

Seller waives the standard warranty on the following components and systems: Downstroke Baler bale ejection system - to include dump rods, dump handles, dump trays and associated components; Sonozaire hoses and fittings; Broken or lost machine keys; Broken or bent limit switch arms; All fuses and thermal / voltage / current limiting devices; Guide islands, wheel-stops, and anchor bolts; Container nose rollers.

RETURN OF PRODUCTS OR SERVICE PARTS FOR REPAIR OR CREDIT

Unless Seller shall have authorized or permitted the return of any products or parts, in writing, or by phone with Return Material Authorization (RMA) Number assigned by J.V. Manufacturing, Inc. to the specified product or parts, seller shall not be obligated to accept from Buyer any products or parts returned, nor to make any exchange thereof, nor to credit Buyer therefor.

Warranty Policy, continued

NOTICE OF CLAIMS

- A) Buyer must notify Seller immediately by e-mail, phone, writing, or fax, of any defect, malfunction, or nonconformity after he or she knows or has reason to know the basis of any claim, and in no event more than ten days thereafter. Within 24 hours after receiving notice from the buyer, Seller will authorize repair or replacement of the defective part. (1) J.V. Manufacturing, Inc., at its sole discretion, will have the option to make repairs or authorize a distributor or third party to make repairs. (2) All claims for repairs must be accompanied with a Warranty Job Order Number. Failure to obtain a Job Order Number will relieve Seller from all liability.
- B) Failure to give the notice prescribed by Subsection shall relieve the seller from all liability on any claim in respect to any transaction growing out of this warranty.
- C) The provisions of this shall survive the termination of any other portions of this warranty.

COMMON CARRIERS AGENTS OF DISTRIBUTOR

Whenever Seller shall deliver or cause to be delivered to a common carrier any goods ordered by Buyer, whether the particular carrier shall have been designated in the shipping or routing instructions of the Buyer or not, Seller shall not be responsible for any delays or damages in shipment and the common carrier, to which Seller shall deliver goods shipped to the Buyer, is declared to be the agent of the Buyer.

COMPLETENESS OF INSTRUMENT

This instrument contains all of the agreements, understandings, representations, conditions, warranties, and covenants made between parties hereto. Unless set forth herein, neither party shall be liable for any representations made, and all modifications and amendments hereto must be in writing.

COMPLETENESS OF INSTRUMENT

This instrument contains all of the agreements, understandings, representations, conditions, warranties, and covenants made between parties hereto. Unless set forth herein, neither party shall be liable for any representations made, and all modifications and amendments hereto must be in writing.

NO IMPLIED WAIVERS

The failure of either party at any time to require performance by the other party of any provision hereof shall not affect in any way the full right to require such performance at any time thereafter. Nor shall the waiver by either party of a breach of any provision hereof be taken or held to be a waiver of the provision itself.

CONTROLLING LAW

The validity, interpretation, and performance of this warranty shall be controlled by and construed under the laws of the State of Arkansas, the state in which this warranty is being executed. It is understood, however, that this is a general form of warranty, designed for use in the United States wherever the Seller may desire to sell its products and that any provision herein which in any way contravenes the laws of any state or jurisdiction shall be deemed not to be a part of this warranty therein.

BUYER NOT AN AGENT

This warranty does not constitute the Buyer as the agent or legal representative of the Company, or the Company as the agent or legal representative of the Buyer for any purpose whatsoever. Neither party is granted any express or implied right or authority by the other party to assume or create any obligation or responsibility on behalf of or in the name of the other party, or to bind the other party in any manner or thing whatsoever.

FINALITY OF THIS WRITING

The parties intend this document to be the final expression of their agreement and it is intended also as a complete and exclusive statement of the terms of their agreement. No course of prior dealing between the parties and no usage of the trade shall be relevant to supplement or explain any term used in this document. Acceptance or acquiescence in a course of performance rendered under this document shall not be relevant to determine the meaning of this contract even when the accepting or acquiescing party has knowledge of the nature of the performance and opportunity for objection.

OPTIONAL EXTENDED WARRANTY

Call for details.

Warranty Procedures

To request a warranty repair:

1. All warranty repairs must be administered through **CRAM-A-LOT®** Customer Support. Failure to contact Customer Support before performing repairs may result in the denial of your warranty claim and may void the warranty on your machine.
2. Contact Customer Support by phone, fax, or e-mail, as soon as possible after identifying any defect, malfunction, or nonconformity.
3. Please provide the following information when contacting Customer Support for service: Customer name / Store number, Model Number, Serial Number, Shipping Address, Billing Address, and a description of the defect, malfunction, or nonconformity.
4. A Customer Support representative will open a service order and dispatch a Factory Authorized Service Technician to assess the repairs at the machine location within 24 hours.
5. The service technician will make repairs or order any necessary parts to correct the defect, malfunction, or nonconformity. Parts will be delivered to the Service Technician or to the customer's shipping address, at the discretion of the Customer Support representative.
6. The service technician will correct the defect, malfunction, or non-conformity to the customer's satisfaction. Any parts or components that have been diagnosed as defective will be returned to be evaluated by **CRAM-A-LOT®** Quality or Engineering Department personnel, or the vendor who supplied the part, as determined by **CRAM-A-LOT®** Customer Support
7. The warranty claim will be denied if any parts are found to be defective as the result of damage or neglect on the customer's part. In this case the customer will be notified and invoiced for the repair.

CRAM-A-LOT® CUSTOMER SUPPORT

Tel: 800-754-4290

Fax: 479-751-7870

Hours: 8:00a.m–5:00p.m. CST

Monday – Friday

service@jv.com